

out (1)
by

Submission date: 06-Feb-2021 10:55PM (UTC-0600)

Submission ID: 1503394171

File name: out_1.pdf (925.24K)

Word count: 6834

Character count: 37085



1
Customer Value Determination and its Implications in Customer Loyalty Hotels

Fitrizal Fitrizal¹, Nandan Limakrisna^{2*}

¹Universitas Putra Indonesia YPTK, Padang, Indonesia, ²Universitas Persada Indonesia YAI, Jakarta, Indonesia.

*Email: amarta.nandan@gmail.com

Received: 29 December 2018

Accepted: 28 February 2019

DOI: <https://doi.org/10.32479/imm.7612>

1
ABSTRACT

The low customer loyalty to Four-Star Hotels in West Sumatera province was allegedly caused by customer relationship management (CRM), service quality and customer value are still low. The purpose of this research was to determine and analyze the effect of CRM and service quality partially or jointly towards customer value. To determine and analyze the effect of CRM, service quality and customer value partially or jointly on customer loyalty. The population of the study are 205 customers Four Star Hotels in West Sumatera province. The method used in this research is a descriptive survey method and explanatory survey with a sample size using rule 1:5 of 205 respondents, as well as data analysis method used is structural equation modeling with Lisrel 8.51 application program. Based on the research results, obtained following research finding that CRM, service quality and customer value proven to have positive and significant impact on customer loyalty with a contribution of 84% while the remaining 16% are influenced by other factors. Based on partial view customers value the most dominant influence on customer loyalty.

Keywords: Customer Relationship Management, Service Quality, Customer Value, Customer Loyalty

JEL Classifications: M21, M31, Z33

1. INTRODUCTION

West Sumatra Province (West Sumatra) is very rich in tourism potential, in the form of natural and cultural beauty. The West Sumatra community is also famous for its hospitality and inherent eastern culture that can be a mainstay in supporting the tourism sector. Foreign and Local's visit increased from year after year where 2016 rose 96.9% from 2015 and 2017 rose 5.85% from 2016.

The development of tourist and foreign visits and the tourism industry must be supported by hotels, restaurants and other facilities. In 2017, the number of four-star hotels operating in West Sumatra amounted to 11 hotels, which were only 8 hotels before the earthquake. The average occupancy rate is 53.16%.

Room occupancy rate (TPK) of four-star hotels in West Sumatra in 2016 declined (West Sumatra Tourism Service) reached an average of 50.44 percent, a decrease in the growth of room occupancy rates was suspected to be increasingly sharp competition and indicated a decrease in customer loyalty. Of all the occupancy rates that are loyal to the hotel are still low, this can be seen from the Table 1.

From Table 1, it can be seen that customer loyalty to four-star hotels in West Sumatra continues to decline from year after year. The number of guests that returned to 2015 was 7791 (31.01%), 2016 were 7188 people (26.22%) and 2017 fell to 6276 people (21.21%).

The lack of customer loyalty to four-star hotels was allegedly caused by customer value, and low customer relations and service quality.

Table 1: Four star hotel customer loyalty levels in West Sumatra

Year	The occupancy rate (%)	Returning guests (%)	Number of guests (people)	Number of returning guests (people)
2015	47.55	31.01	25698	7791
2016	50.44	26.22	26114	7188
2017	53.16	21.21	28077	6276

Source: West Sumatra Province Tourism Office (processed)

According to (Riorini and Widayati, 2015), when management determines loyalty to customers as the highest factor of a company, the main concern are how to find determinants or factors that direct customer loyalty (determining factors or main driver of customer loyalty). Longitudinal studies show that the main drivers of customer loyalty in the long term are: Customer satisfaction, service quality, brand image, perceived value, trust, customer relationships, switching costs, waiting time, reliability/dependability.

Loyalty is a post-purchase or product usage behavior. The form of loyalty that can be seen empirically is repurchasing and recommendation (Limakrisna, 2008).

In the midst of the decline in customer loyalty to four-star hotels in West Sumatra, hotel business people must maintain business continuity and try to find opportunities by utilizing the advantages possessed by the company so that they remain in this business. One way that can be taken by the hotel business is to build customer loyalty by retaining existing customers so that they are loyal and not move to other competitors.

The results of research conducted by (Rizan et al., 2014) show that customer loyalty can be formed by providing superior room facilities and supported by individual services to hotel customers. Other research conducted (Ali, 2016), shows that hotel customer loyalty will be influenced by space and time. Whereas (Martinez and del Bosque, 2013), stated that loyal hotel customers do not necessarily have high commitment to the hotel. The latest research results from (Wijoyo, 2014) state that the loyalty to hotel customers in West Java is determined by the value of the hotel services themselves and the relations of the hotel customers are good.

From the statement by, it can be learned that the formation of loyalty can be done by creating value where the value received by the customer is a comparison between total customer benefits and total customer costs (Grönroos and Ravaid, 2011). Total customer values are a set of benefits expected by customers of a given product or service, while total customer costs are a set of costs incurred by customers in evaluating, obtaining, using and disposing of a product or service. Therefore, the value received by customers will be different to each customer, given the customer's expectations for a product or service will vary. Thus, the greater the benefits customers feel compared to the costs that must be incurred, the greater the value received by the customer. If the customer value is greater than the competitor, it will create superior customer values. Therefore, it is important to companies to create superior values for their customers.

In the hospitality industry the creation of superior value can be done by providing hotel rooms and all of their facilities well

through providing superior services, such as agile, friendly, and attentive employees (Coelho and Henseler, 2012). For hotel customers, emotional factors also play an important role in forming values through perceived comfort and which products or services create unforgettable emotional experiences. Five areas that must be considered by the hotel, namely products, employees, arrivals, values and locations. The products that are related to the product include the rooms provided by the hotel, namely the design of the rooms, the comfort of beds and rooms, and the cleanliness of rooms and hotels. Other additional product attributes include good food, pleasant atmosphere, tranquility and security. According to this study, hotel employees have a significant influence on the feelings of hotel customers. Hotel customers expect hotel employees to be friendly, friendly, know a lot about the hotel, and pay attention to the needs of its customers. Hotel customers will feel safe and comfortable knowing that hotel employees can be trusted to be related to valuable items brought by customers, messages to be conveyed to customers, and wake-up calls. On arrival, hotel customers expect to be welcomed by the attitude to the friendly and polite hotel employees. The facilities provided by the hotel in the form of complimentary gifts, food or drinks, loyalty programs, and special discounts, are of added value for hotel customers. Having a location close to the destination of hotel customers staying provides comfort for hotel customers. The location that is considered strategic is that it is close to shopping centers, tourism and entertainment venues, and business centers. This is in line with the research conducted by Ali, (2016) that other factors to consider in the selection of hotels, in addition to the provision of hotel rooms and all of their facilities, are locations and how popular a hotel is.

The formation of value itself is not to maximize income from a single transaction, but to build lasting relationships with customers where both parties adapt to each other so that they compete not exclusively based on price, but also based on the ability of procedures to help customers create value of themselves. This can be built through relationships of interested parties of the company or stakeholders, one of which is the customer. The term relating to customer relations in the current business context is known as customer relationship management (CRM). CRM is a corporate strategy used to pamper customers so they don't turn to competitors. In this case the company provides a touch of individual service by treating customers as kings. Companies need a customer database that contains detailed customer information that plays an important role in CRM. The customer database in the hospitality industry can contain the name and address of the customer, work, destination of stay, and other preferences such as the type of room, food ordered, newspaper read, and when the customer last stayed at the hotel. This information is a very valuable asset for the hotel in establishing relationships of customers.

In establishing relationships of customers, the company treats each of its customers differently so that the company should know customer behavior so that an approach can be established on how the company will do in establishing lasting relationships of customers. Customer behavior describes how an individual makes decisions on using resources such as money, time, and effort, for good or services produced. This includes what, why, when, where, how often he buys the product or service, and how often he uses the product or service. It was therefore important to the hotel to know what a hotel guests wanted by staying at a hotel, why he chose to stay at a hotel, when he decided to stay at a hotel, at the hotel where he decided to stay, and how often he stayed at the hotel. The answers to the questions about can to help the hotel in implementing CRM programs, which consist of continuity of marketing, one to one marketing and partnering programs (Kassim et al., 2009).

9

Relationships of customers are the addition of value that is above the product itself, which in this case the hotel service industry products are derived from interactions between hotel employees and the customers themselves. Therefore, in establishing relationships with customers there is a need for information exchange between the hotel and hotel customers. Not only the hotel that provides information about one direction, but customers must also provide information to the hotel, both in the form of things that is liked, suggestions, and criticism. This will lead to mutual relations between the hotel and its customers, therefore feedback from customers is very important to the hotel.

In the hospitality industry, it is suspected that the hotel has difficulty in obtaining feedback from customers, which makes it difficult for the hotel to establish deeper relationships with customers. (Baird and Parasnis, 2011) states that the fact that exists in the application of CRM in Asia is the difficulty of creating feedback from customers. In addition, most hotels are also more focused on determining how to get more customers, not how to maintain existing customers, such as the main purpose of CRM (Ang, 2011). This indicates that the hotel has not been able to package the CRM program properly so that it can arouse customers in giving feedback to the hotel.

The formation of values other than obtained from customer relations, can also be formed into information obtained by customers. Thus, the company must be able to provide correct information by utilizing the communication process of all parties, such as customers, suppliers, retailers and other parties who have an interest in the company. Submission of this information can be done through various kinds of promotions carried out by the company. In addition, the results of research conducted by (Mao, 2010) above that customer loyalty can be formed by providing superior room facilities and supported by individual services to hotel customers.

In this case the four-star hotel in West Sumatra is required to establish long-term relationships of its customers through CRM and maintain service quality in order to create superior customer values so that it will create hotel customer loyalty.

The increasing number of four-star hotels in West Sumatra is increasingly sharp competition. The level of intense competition has made it difficult for companies to increase the number of customers. In existing markets, there are too many products of various advantages and more value offered by competitors, making it difficult for companies to capture competitors' market share. On the other hand, to enter new markets requires considerable costs. This shows that the cost of getting new customers is 6 times greater than the cost of maintaining customers (Ren et al., 2016).

In the era of globalization, the level of intense competition has made it difficult for companies to increase the number of customers. In existing markets, there are too many products of various advantages and more value offered by competitors, making it difficult for companies to capture competitors' market share. On the other hand, to enter new markets requires considerable costs. This shows that the costs needed to obtain new customers are 6 times greater than the cost of retaining customers (Ali, 2016). Marketers generally want that the customers they create can be maintained forever. This is not an easy task considering changes can occur at any time, both changes in the customer, such as tastes and psychological aspects and changes in environmental conditions that affect the psychological, social and cultural aspects of the customer.

43

The above changes in the environment have an impact on the customer's buying decision process. Although marketers already have a customer segment that is considered loyal, intense competition pressures are deliberately directed at changing customer loyalty.

10

This loyalty is a post-purchase or product usage behavior. The form of loyalty that can be seen empirically is repurchasing and recommending (Riorini and Widayati, 2015).

In fact, to maintain customers of a company, steps is needed to provide good quality services for products and services in order to provide satisfaction and generate loyalty to consumers (Martínez and del Bosque, 2013).

In the past few years, customer satisfaction has become the main goal for business companies since it is judged to affect customer and company retention (Rizan et al., 2014). Customer satisfaction is seen from lack of price sensitivity, lack of influence over other competitors, buying several products both services and goods and being loyal for a long period of time.

In order to achieve this level, the company seeks to build relationships of customers, this is carried out only if the business is in line with its impact on long-term customer value creation (El-Adly and Eid, 2016).

According to (Kassim et al., 2009), "The focus on CRM has been on building an effective database with details of previous purchaser and the utilize this to find ways of delivering value."

The focus on CRM is to build effective data onto previous purchase details and be used to find ways to provide value of customers

(Ang, 2011). One way to find out the existence of a relationship is to measure how many times consumers make purchases of the same company.

If there are several continuous purchases, or contacts that has been effective against a certain period of time, then the relationship of the consumer has developed. Customer Retention is the marketing goal of keeping your customers from going to the competition. The rule of thumb is that there are times when the customer is not to acquire a new one. This is a major in them to CRM (Uncles et al., 2013).

Customer Retention can be interpreted as a marketing goal to keep customers from moving to competitors. The main rules show that costs of customers are 5-10 times lower than getting new customers.

This is the main driver towards CRM. The dynamics that occurs to the service sector can be seen from the development of various industries that are now increasingly aware of the need to increase orientation to customers or consumers. Many studies have been conducted with the aim at proving factors that can affect customer loyalty to a product.

2. LITERATURE REVIEW

2.1. Customer Loyalty

(Wijoyo, 2014) explain when management determines customer loyalty as the highest factor of a company, the main concern are how to find determining factors or main driver of customer loyalty. Longitudinal studies show that the main drivers of customer loyalty to the long run are: Customer satisfaction, service quality, brand image, perceived value, trust, customer relationships, switching costs, waiting time, reliability/dependability.

Basically customer loyalty is defined as a person's loyalty to something. According to (Mittal, 2016) customer loyalty is a commitment to persist in depth to repurchase or re-subscribe to selected products or services consistently in the future, even though the influence of the situation and marketing efforts has the potential to cause behavioral changes. From Oliver's definition it can be said that loyal customers have a kind of relatively permanent fanaticism in the long term towards a product/service or a company that has become his choice.

Whereas Martínez and del Bosque (2013) states that it has become apparent that customer satisfaction is no longer the key to the company's success, but customer loyalty is the dominant key to a business's success. Customer loyalty is defined as customers that are satisfied with the company's products or services and they become enthusiastic word-of-mouth advertisers. Furthermore, he extends loyalty not only to products or services, but also to the entire portfolio of company products and services as part of life spans or in other words brand loyalty forever.

Another concept regarding customer loyalty states that the concept of loyalty is more directed towards behavior (behavior) compared to the attitude (attitude) and a loyal customer will show purchasing

behavior that can be interpreted as a regular purchase pattern and for a long time, carried out by the unit-unit maker or decision maker (Baidya and Ghosh, 2014).

From the description of it can be concluded that the notion of loyalty is a person's loyalty in the long term, where they make regular purchases and buying behavior are not done by randomizing (non-random) several decision units. Besides the characteristics of loyal customers is someone that is immune to the attractiveness of other products and always gives input to the company.

2.2. CRM

According to (Kassim et al., 2009), CRM is an approach from companies to identify, implement, obtain, retain customers through various capabilities in an integrated manner. According to (Baird and Parasnis, 2011) CRM is a modification and learning of consumer behavior every time and every interaction, treating customers and building strength between consumers and companies. Basically, CRM is managing relationships/relationships of customers through the company's ability to improve company performance in the future.

The key to the success of CRM is:

- a. Identifying the right consumer value of a particular business, the ability to identify value of consumers is the key to success in implementing CRM. Because value is what consumers get is greater than what consumers give. In other words the benefits received are greater than the costs made.
- b. Understand the relative importance of values towards each customer segment. Understanding the relative importance of each segment mean understanding the needs, desires and expectations of different customers. The difference in question is not only based on demographic and geographic aspects but also on psychographic aspects.
- c. Determine whether these values will affect earnings in positive circumstances. Using business to build relationships must correlate with profits that will be obtained, meaning that the value to be given to consumers must contribute to the achievement of profits for consumers and companies.
- d. Communicate and provide the right value to each customer segment of a way that customers want to receive information. The accuracy of information delivery of consumers' needs to get an equally important portion. This involves various things that consumers want.
- e. Measuring the results from a measure of return on investment, the value given to consumers of course must be measured in such a way, such as whether the rate of return to the business of the invested value is quite large.

According to (Ang, 2011) there are three concepts from CRM. The first concept is customer value creation that aims not only to maximize revenue from a single transaction, but a competitive advantage that is not only based on price, but also based on the ability of the provider to help customers generate value of themselves and to foster long-term relationships with customers. The second concept are to look at the product as a process of this case the difference between goods and services no longer

means. The product is seen as an entity that includes exchanges of processes carried out by the provider and the processes carried out by the customer. Through this exchange provider competence is partially transferred into customer value creation. Because of that product differentiation becomes process differentiation so as to open unlimited opportunities that produce various kinds of relations. The third concept are the responsibility of the provider. A company can foster stronger relationships only if the company is responsible for building these relationships and offers its customers to produce values of themselves.

Kassim et al. (2009) suggested that there are three CRM programs that must be implemented to achieve CRM goals, namely sustainable marketing (continuity marketing), individual marketing (one to one marketing) and partnership programs (partnering programs). Continuity marketing (continuity marketing) is a joint program to maintain and increase customer loyalty. Individual marketing programs (one to one marketing) is marketing programs carried out individually aimed at fulfilling satisfaction with the unique needs of customers that are focused on one customer at a time or period while the partnership program (partnering program) is a program where the company engages in relationships partnership between the form of cooperation with other parties to serve and meet customer needs.

Great attention to retaining customers has caused many companies to try to develop a continuity marketing program aimed at retaining customers and increasing their loyalty (Evanschitzky et al., 2012). Continuity marketing is applied by applying a membership system, providing discounts, vouchers, special facilities and reward points to customers.

The application of the One to one marketing program can be seen from the friendliness and politeness of employees, speed and skills of employees, handling complaints by employees, greetings by employees to customers, and giving greeting cards to customers. The partnership program seen by the company will be able to create relationships of customers, grow and maintain long-term relationships of customers, and create and enhance loyalty to partnerships between other parties such as convention rooms, salons, cafes, parking and others (Gervais, 2016; Mittal, 2016).

For consumers in the mass market, this program is usually in the form of membership card programs and loyalty cards where consumers are often given awards that can be in the form of individual special services, points for upgrades, discounts, and cross purchases.

In the hospitality industry, customer relations are very important to creating customer loyalty. In this case the relationship will create more value of customers compared to other factors such as prices and product features, thus increasing lifetime value for customers. Famous hotels strive to provide more than just customer satisfaction and ensure value of a relationship rather than just transactional. Research shows that customer satisfaction is not enough to build loyalty. CRM in the hospitality industry is based on the basic principle that good service does not guarantee customer satisfaction and customer satisfaction does not guarantee loyalty.

Therefore there arises the need for strong customer relations to build loyalty. For hotel products, customer relations are based on the moment of truth which when combined with the unique characteristics of the hospitality industry will attract the attention to service providers to prioritize customers. According to (Kassim et al., 2009) CRM in the hospitality industry is a continuous process of managing the moment of truth and looking for opportunities in creating customer value with the aim at building customer loyalty based on constant interactions between customers and products and hotel employees.

2.3. Service Quality

(Misailovic et al., 2010) define service quality as the difference between the reality and the expectations of customers for the services they receive. Quality services will create satisfaction with service users that ultimately can provide several benefits, including harmonious relationships between service providers and customers, providing a solid basis of repurchase, and creating customer loyalty.

(Emrah Cengiz Ph, 2010) Balancing Customer Perceptions and Expectations, reveals the results of his research that there are ten criteria or dimensions that can be used to assess service quality.

The ten dimensions of service quality are: "Tangibles, reliability, responsiveness, competence, courtesy, credibility, security, access, communication, and understanding the customer." These dimensions are not always related to each other because there are overlapping dimensions, such as credibility and security dimensions.

To find out the service quality that is perceived by the customer, Zeithaml-Parasuraman-Berry provides a measure of customer satisfaction that is located in 5 (five) dimensions of service quality according to what the customer says, namely:

1. Tangibles (quality of service in the form of office infrastructure, computerized administration, waiting rooms, information sites and so on);
2. Reliability (ability and reliability to provide trusted services);
3. Responsiveness (ability to help provide services quickly and precisely, and responsive to customer desires);
4. Assurance (ability and friendliness, as well as polite manners in convincing customer trust);
5. Empathy (firm attitude but attention from employees to customers).

2.4. Customer Value

Hilton et al. (2012) explain the concept of customer values giving an overview of a company's customers, consider what they want, and believe that they benefit from a product. The concept of customer values to indicate a strong relationship to customer or customer satisfaction. Where the concept describes evaluative considerations of customers about the products they consume. The value that customers wants is formed when they shape the perception of how well a product is playing in a situation of use. They evaluate the usage experience of the same attributes, as explained above that the attributes referred to here are brand and service excellence for the product. The value received directs the

formation of feelings of overall satisfaction. Overall satisfaction is the customer's feelings in response to an evaluation of one or more customer experiences in the use of a product with the achievement of satisfaction levels.

The attention to consumers and marketers to the concept of value increases and value itself is considered as a source of competitive advantage in the future. At present customer value is very influential on business in achieving short and long term goals. A business that creates value of customers is expected to produce better financial performance.

3. RESEARCH METHOD

The research method used is quantitative analytical research with a descriptive and verified analysis approach, research data and information directly at the place where the research was conducted. Research that is descriptive aims to obtain an overview of the variable variables studied. The design of this study is causality, namely the type of investigation that states the existence of a relationship between the independent variables, namely CRM, Service quality and customer trust in Hotel Customer Value and Loyalty based on causal relationships. The unit of analysis of this study is a four-star hotel in West Sumatra. The observation unit of this study is customers that have repeatedly stayed at the hotel.

Whereas verification research is to test hypotheses through data collection of the field, which in this study will be tested whether CRM and Service quality affect Hotel Customer Value and Loyalty. The time period of this study is time horizon which is crossing section, namely information about a portion of the population (respondent's sample) collected directly on the scene empirically, with the aim to find out the opinions of some populations of the object being studied. The dissertation research time is from April 2017 to August 2017. The population level determined in this study consisted of all customers that had settled in 11 4-star hotels in West Sumatra with a total of 6245 people. In this study the sample size was determined in the form of a statistical test to be used namely structural equation models or structural equation modeling (SEM). Thus the minimum sample size of this SEM is 205 respondents.

To test hypotheses 1 through 7, it was tested using SEM. The reason for choosing this method is its ability to measure constructs indirectly, namely through its indicators and simultaneously analyzing indicator variables and latent variables.

4. RESULTS AND DISCUSSION

The full model of the SEM equation using the LISREL 8.51 program obtained two path diagram models, one standardized model and a model t-values, each model as shown in the following Figures 1 and 2.

Based on Figures 1 and 2, the above calculations are then β parameters (loading factors/structural dimensions) structural in both exogenous and endogenous models. This test is intended

to determine the causal relationship or the effect of attenuation variables with other latent variables indicators of each latent variable (construct).

The results obtained using the Lisrel 8.70 program for the SEM below.

$$CV = 0.33*CR + 0.51*SQ, \text{ Errorvar.} = 0.42, R^2 = 0.58 \quad (1)$$

(0.14)	(0.11)	(0.05)	(0.003)
2.40	4.638,	4019.33	

The t_{count} of the influence of customer relationship on customer value is $2.40 > 1.96$ ($t_{\text{count}} > 1.96$), so that it can be said to be significant, customer relationship partially has a significant effect on the value of the customer.

While the t_{count} of the influence of service quality on customer value is $4.63 > 1.96$ ($t_{\text{count}} > 1.96$), so that it can be said to be significant, Service Quality partially affects the Customer Value of Four Star Hotels in West Sumatra Province.

Then together can be seen from the value of F_{count} in the above equation which is equal to $193.33 > 3.84$ so that together the Management of Customer Relations and Service Quality has a significant effect on the Customer Value of Four-Star Hotels in West Sumatra.

The SEM of Customer Relations Management, Service Quality and Customer Value for Customer Loyalty (t-value) based on those obtained using the Lisrel 8.51 program are as follows.

$$CL = 0.46*CV + 0.37*CR + 0.23*SQ, \text{ Errorvar.} = 0.16, R^2 = 0.84 \quad (2)$$

(0.11)	(0.12)	(0.09)	(0.04)	(0.002)
4.25	3.09	2.37	4.16	353.50

Based on the above equation, the t_{count} of the influence of CRM on Customer Loyalty is $3.09 > 1.96$ ($t_{\text{count}} > 1.96$), so that it can be said to be significant, CRM partially has a significant effect on Customer Loyalty.

While the t_{count} of the influence of Service Quality on Customer Customer Loyalty is $2.37 > 1.96$ ($t_{\text{count}} > 1.96$), so that it can be said to be significant, Service Quality partially affects Customer Loyalty in Four Star Hotels in Sumatra Province West.

The t_{count} of the influence of Customer Value on Customer Customer Loyalty is $4.25 > 1.96$ ($t_{\text{count}} > 1.96$), so that it can be said to be significant, the Customer Value partially affects Customer Loyalty in Four Star Hotels in West Sumatra Province.

Then simultaneously can be seen from the value of F_{count} in the above equation that is equal to $353.05 > 3.84$ so that together Customer Relations Management, Service Quality and Customer Value significantly influence Customer Loyalty Four Star Hotels in West Sumatra.

The simultaneously influence of CRM, service quality and customer value on customer loyalty is $0.8385 \approx 0.84$ or $R^2 = 0.84$.

Figure 1: Hybrid model results of structural equation modeling (standardized coefficient) calculation

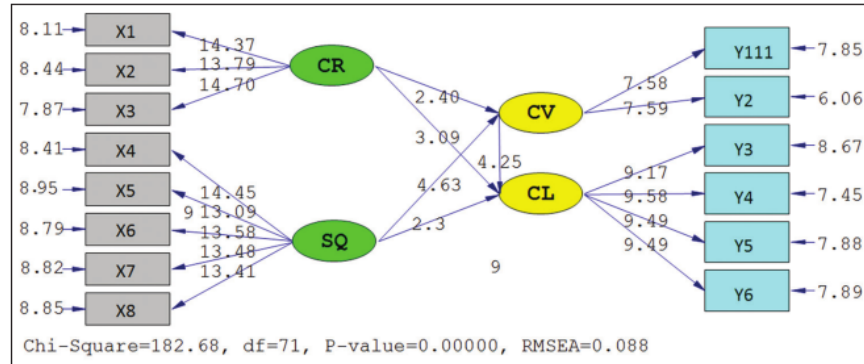
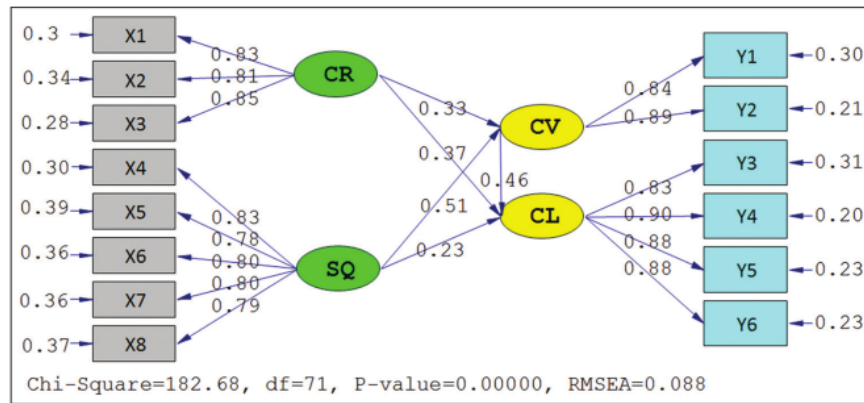

Figure 2: Hybrid model of structural equation modeling calculation results (t-value model)



1. The contribution to the direct effect of CRM variables on loyalty variables is contributed by 13.69%. While the large contribution to the indirect influence of customer relations management on loyalty to service quality is 5.36%, and the contribution to indirect effects on CRM variables on customer loyalty variables through customer value is 10.04%, so the total contribution of the variable influence CRM for customer loyalty variables is 29.09%.
2. The contribution to the direct effect of the service quality variable on the loyalty variable is the contribution to 5.29%. While the contribution to indirect service quality of loyalty to CRM is 5.36%, and the contribution to indirect service quality variables to customer loyalty variables through customer value is 6.45%, so the total contribution of the variable quality service to customer loyalty variable is 17.10%.
3. The contribution to the direct effect of customer values variables on the loyalty variable is the contribution to 21.16%. While the large contribution to the indirect influence of customer values on loyalty to CRM is 10.04%, and the large contribution to the indirect effect of customer value variables on customer loyalty variables through service quality is 6.45%, so that the total contribution influences the value variable customers to customer loyalty variable is 37.66%.
4. The amount of total contribution to influence both directly and indirectly the variable of customer relations management, service quality and customer value together towards customer

loyalty of Four Star Hotels in West Sumatra is 84%, with the most dominant factor partially being the customer value factor with contribution of 37.66%.

The results of the above tests indicate that directly the CRM variables and service quality affect the customer value variable with a contribution to 58%. Then the CRM variables and service quality directly influence the service loyalty variable from a contribution to 29.70%. But through customer value, the customer relations management and service quality variables influence loyalty increases from a contribution to 84%. This is in accordance with the results of the research put forward by (Kassim et al., 2009; Rizan et al., 2014). Likewise (Ali, 2016; Li and Hsu, 2016; Ren et al., 2016; Tajeddini, 2010) from the results of his research in line with this study that CRM affects hotel customer satisfaction, and has implications for hotel customer loyalty.

5. CONCLUSION

Customer values of Four Star Hotels in West Sumatra, especially in the value of customers from customers will be able to be improved if the Four Star Hotel Management is able to improve Service Quality, especially in the tangibles aspect and supported by improving the ability to manage customer relations, especially on the partnering program.

Customer loyalty to Four Star Hotels in West Sumatra, especially the elements of the use of hotel facilities will be able to be improved if Four Star Hotels in West Sumatra is able to increase Customer Value, especially in the financial sector, and are supported by the ability to improve service quality, especially in tangibles CRM especially on the partnering program. For overseas market share, the company seeks to establish cooperation with parties related to tourism, such as overseas travel agents, following tourism expos and exhibitions abroad and conducting regular visits for customers of companies abroad to maintain existing cooperation and to seek new customer customers. For domestic market share, the Company must strive to increase the number of its customers, by holding gatherings with local tourism actors, travel agents, airline companies and Tourism Dinars. As well as the Company actively participated in various expos that featured tourism in Indonesia.

The management of four-star hotels in West Sumatra together increases Customer Relations Management and Service Quality because it is proven together to have a positive and significant effect on Customer Values. Customer Relations Management, Service Quality and Customer Value Four Star Hotels in West Sumatra are jointly increased so that customer loyalty increases.

REFERENCES

- Ali, F. (2016), Hotel website quality, perceived flow, customer satisfaction and purchase intention. *Journal of Hospitality and Tourism Technology*, 7(2), 213-228.
- Ang, L. (2011), Community relationship management and social media. *Journal of Database Marketing and Customer Strategy Management*, 18(1), 31-38.
- Baidya, M., Ghosh, G. (2014), An empirical investigation of repeat buying behavior of customers of two brands in India. *Journal of Indian Business Research*, 6(3), 255-268.
- Baird, B.C.H., Parasnis, G. (2011), From social media to social customer relationship management. *Strategy and Leadership*, 39(5), 30-37.
- Baird, C.H., Parasnis, G. (2011), From social media to social customer relationship management. *Strategy and Leadership*, 39(5), 30-37.
- Coelho, P.S., Henseler, J. (2012), Creating customer loyalty through service customization. *European Journal of Marketing*, 46(3/4), 331-356.
- El-Adly, M.I., Eid, R. (2016), An empirical study of the relationship between shopping environment, customer perceived value, satisfaction, and loyalty in the UAE malls context. *Journal of Retailing and Consumer Services*, 31, 217-227.
- Emrah Cengiz Ph. (2010), Measuring customer satisfaction : Must or not ? *Journal of Naval Science and Engineering*, 6(2), 76-88.
- Evanschitzky, H., Ramaseshan, B., Woisetschläger, D.M., Richelsen, V., Blut, M., Backhaus, C. (2012), Consequences of customer loyalty to the loyalty program and to the company. *Journal of the Academy of Marketing Science*, 40(5), 625-638.
- Gervais, J. (2016), The operational definition of competency-based education. *The Journal of Competency-Based Education*, 1(2), 98-106.
- Grönroos, C., Ravald, A. (2011), Service as business logic: Implications for value creation and marketing. *Journal of Service Management*, 22(1), 5-22.
- Hilton, T., Hughes, T., Chalcraft, D. (2012), Service co-creation and value realisation. *Journal of Marketing Management*, 28(13-14), 1504-1519.
- Kassim, K.M., Bahari, A., Kassim, N., Ramli, N., Abdul, N. (2009), Retaining customers through relationship marketing in an Islamic financial institution in Malaysia. *International Journal of Marketing Studies*, 1(1), 66-71.
- Li, M., Hsu, C.H.C. (2016), Linking customer-employee exchange and employee innovative behavior. *International Journal of Hospitality Management*, 56, 87-97.
- Limakrisna, N. (2008), The influence of service quality and customer's relationship toward pt.bank negara indonesia bandung branch's image. *Jurnal Ilmiah Ekonomi Bisnis*, 13, (3), 20-30. Available from: <http://www.ejournal.gunadarma.ac.id/index.php/ekbis/article/view/169>.
- Mao, J. (2010), Customer brand loyalty. *International Journal of Business and Management*, 5(7), 213-217.
- Martinez, P., del Bosque, I.R. (2013), CSR and customer loyalty: The roles of trust, customer identification with the company and satisfaction. *International Journal of Hospitality Management*, 35, 89-99.
- Misailovic, S., Sidiroglou, S., Hoffmann, H., Rinard, M. (2010), Quality of Service Profiling. Vol. 1. In *Proceedings of the 32nd ACM/IEEE International Conference on Software Engineering-ICSE'10*. p25.
- Mittal, B. (2016), Retrospective: Why do customers switch? The dynamics of satisfaction versus loyalty. *Journal of Services Marketing*, 30(6), 569-575.
- Ren, L., Qiu, H., Wang, P., Lin, P.M.C. (2016), Exploring customer experience with budget hotels: Dimensionality and satisfaction. *International Journal of Hospitality Management*, 52, 13-23.
- Riorini, S.V., Widayati, C.C. (2015), Relationship commitment dan customer engagement: Stimulus serta konsekwensi padakonsumen pengguna transportasi darat. *Mix: Jurnal Ilmiah Manajemen*, 5(3), 20-30.
- Rizan, M., Warokka, A., Listyawati, D. (2014), Relationship marketing and customer loyalty: Do customer satisfaction and customer trust really serve as intervening variables? *Journal of Marketing Research and Case Studies*, 2014, 1-12.
- Tajeddini, K. (2010), Effect of customer orientation and entrepreneurial orientation on innovativeness: Evidence from the hotel industry in Switzerland. *Tourism Management*, 31(2), 221-231.
- Uncles, M.D., East, R., Lomax, W. (2013), Good customers: The value of customers by mode of acquisition. *Australasian Marketing Journal*, 21(2), 119-125.
- Wijoyo, A. (2014), Effect of marketing mix variable on honda-ramayana basuki rachmad surabaya customer loyalty with customer satisfaction as variable intervening. *Journal of Marketing Management Petra*, 2(1), 1-13.

© 2019. This work is published under
<http://creativecommons.org/licenses/by/4.0/>(the “License”). Notwithstanding the
ProQuest Terms and conditions, you may use this content in accordance with
the terms of the License.

out (1)

ORIGINALITY REPORT

29%

SIMILARITY INDEX

22%

INTERNET SOURCES

5%

PUBLICATIONS

17%

STUDENT PAPERS

PRIMARY SOURCES

1	www.econjournals.com Internet Source	9%
2	ecoforumjournal.ro Internet Source	3%
3	ojs.usp-pl.com Internet Source	1%
4	Submitted to IUBH - Internationale Hochschule Bad Honnef-Bonn Student Paper	1%
5	Submitted to Universitas 17 Agustus 1945 Surabaya Student Paper	1%
6	Submitted to Anglia Ruskin University Student Paper	1%
7	www.ijstr.org Internet Source	1%
8	Submitted to Universitas Pendidikan Indonesia Student Paper	1%

9	Submitted to Pacific International Hotel Management School Student Paper	1%
10	ijbmer.org Internet Source	1%
11	Submitted to Politeknik Negeri Sriwijaya Student Paper	1%
12	Viany Utami Tjhin, Reza Tavakoli, Robertus Nugroho Perwiro Atmojo. "The determinants affecting e-loyalty: Hospitality industry in Indonesia", 2016 2nd International Conference on Science in Information Technology (ICSITech), 2016 Publication	1%
13	Submitted to Buckinghamshire Chilterns University College Student Paper	1%
14	Submitted to School of Business and Management ITB Student Paper	<1%
15	doaj.org Internet Source	<1%
16	ijecm.co.uk Internet Source	<1%
17	pt.scribd.com Internet Source	

<1%

18

marketing.expertjournals.com

Internet Source

<1%

19

dialnet.unirioja.es

Internet Source

<1%

20

Submitted to Auckland Institute of Studies at St. Helens

Student Paper

<1%

21

Submitted to Coventry University

Student Paper

<1%

22

Submitted to Monash University

Student Paper

<1%

23

jurnal.ubd.ac.id

Internet Source

<1%

24

Submitted to Auston Institute of Management and Technology

Student Paper

<1%

25

www.ijicc.net

Internet Source

<1%

26

ijcrr.info

Internet Source

<1%

27

Submitted to University of Wales central institutions

<1%

28 Submitted to Curtin University of Technology <1 %
Student Paper

29 Submitted to Universitas Diponegoro <1 %
Student Paper

30 Submitted to University of Brighton <1 %
Student Paper

31 Suci Sandi Wachyuni. "THE EFFECTS OF SERVICE QUALITY, CUSTOMER PERCEIVED VALUE, AND CUSTOMER SATISFACTION TOWARDS CUSTOMER LOYALTY OF DAMRI TOUR BUS", Journal of Business on Hospitality and Tourism, 2019 <1 %
Publication

32 ijmp.jor.br <1 %
Internet Source

33 www.mdpi.com <1 %
Internet Source

34 www.thaiejournal.com <1 %
Internet Source

35 www.adobe.com <1 %
Internet Source

36 link.springer.com <1 %
Internet Source

37	www.pressacademia.org Internet Source	<1%
38	www.tandfonline.com Internet Source	<1%
39	www.agba.us Internet Source	<1%
40	Michael Daniel Clemes, Xin Shu, Christopher Gan. "Mobile communications: a comprehensive hierarchical modelling approach", Asia Pacific Journal of Marketing and Logistics, 2014 Publication	<1%
41	emrbi.org Internet Source	<1%
42	www.emeraldinsight.com Internet Source	<1%
43	pdfs.semanticscholar.org Internet Source	<1%
44	www.palmajournal.org Internet Source	<1%
45	Mohammed Ismail El-Adly, Amjad Abu ELSamen. "Guest-based hotel equity: scale development and validation", Journal of Product & Brand Management, 2018 Publication	<1%

46

Nur Komariah, Suryana H Achmad, Rahmat Hidayat. "Comparative Studies: The Effect of Service Quality System toward Customer Satisfaction on TIKI And JNE", 2018 6th International Conference on Cyber and IT Service Management (CITSM), 2018

Publication

<1%

47

wrap.warwick.ac.uk

Internet Source

<1%

Exclude quotes Off

Exclude matches Off

Exclude bibliography On