



## **Design, Testing, and Construction of Special Hybrid Moment Frame Structures for High Rise Building in Indonesia**

**HARI NUGRAHA NURJAMAN<sup>1</sup>, GAMBIRO SUPRAPTO<sup>2</sup>, LUTFI FAIZAL<sup>3</sup> AND BINSAR HARIANDJA<sup>4</sup>**

<sup>1</sup>Persada Indonesia University, Jakarta, Indonesia

<sup>2</sup>PT Wijaya Karya Beton, Tbk, Jakarta, Indonesia

<sup>3</sup>Research Institute of Human Settlement Ministry of Public Work and Housing, Bandung, Indonesia

<sup>4</sup>Department of Civil Engineering, Bandung Institute of Technology, Bandung, Indonesia

**Email:** iappi\_ind@yahoo.com, gambiro@wika-beton.co.id, faizblue\_21@yahoo.com, binsar\_hariandja@ymail.com

**Abstract:** Precast concrete technology for buildings in Indonesia has been developed fastly. Thus far we are accustomed to strong column weak beam concept in the design of earthquake resistant building. In this concept energy dissipation is attained from the formation of plastic hinges in beams. The design refers to ACI 318 (SNI 2847 – 2013: Persyaratan Beton Struktural untuk Bangunan Gedung ) and SNI 1726 - 2012 Tata cara perencanaan ketahanan gempa untuk struktur bangunan gedung dan non gedung. The application of these codes does not allow the structural repairment if damage by strong earthquake. This matter becomes problematic for the users. To overcome this problem, research and development have been carried out in PREcast Seismic Structural System (PRESSSS) by New Zealand and United States (Stefano Pampanin cs). The system uses unbonded post-tensioned tendon in beam-column connection according to ACI TI.2-03 Special Hybrid Moment Frames Composed of Discretely Jointed Precast and Post-Tensioned Concrete Members which updated as ACI 550.3M-13 Design Specification for Unbonded Post-Tensioned Precast Concrete Special Moment Frames Satisfying ACI 374.1. Several projects has applied this system, among others, Tamansari Hive Office Park, TNI-Polri flats and Santo Borromeus Carolus Hospital. The three projects are located in Jakarta, which located in earthquake region in Indonesia. Generally, the design of buildings in Indonesia is categorized as Kategori Desain Gedung (KDG) D, E or F. In this case, the type of building is chosen as Special Moment Resistant Frames (Sistem Rangka Pemikul Momen Khusus, abbreviated as SRPMK). To validate that PRESSSS conforms to SRPMK specifications, some tests have been carried out according to SNI 7834 - 2012 Metode Uji dan Kriteria Penerimaan Sistem Struktur Rangka Pemikul Momen Beton Bertulang Pracetak untuk Bangunan Gedung adopted from ACI 374.01-05 Acceptance Criteria for Moment Frames based on Structural Testing.

**Keywords:** Precast, Recentering, PRESSSS, Unbonded Post-tension Prestressed Concrete, Special Hybrid Moment Frame

### **1. Introduction**

For earthquake influenced region, Particle 21.1.1.8 ACI 318-11 (SNI 2847:2013) [5] permits the use of structural system not conforming to Article 21 if it is demonstrated by experimental evidence and analysis that the proposed system will have strength and toughness equal to or exceeding those provided by a comparable monolithic reinforced concrete structure.

ACI 374 (SNI 7834), “Metoda uji dan kriteria penerimaan sistem struktur rangka pemikul momen beton bertulang pracetak untuk bangunan gedung”, is a standard to establish minimum requirement needed [4] for validation the use of special hybrid moment frame satisfying strong column-weak beam concept according to 21.1.1.8 ACI 318-11 (SNI 2847:2013).

ACI 550.3-13 [1] defines conditions needed for one special type of moment resistant frame not conforming to Article 21 ACI 318-11 (SNI 2847:2013), but may be validated for application in

high seismic region ACI 374.1 (SNI 7834) and ACI 318 (SNI 2847). The frame uses post-tensioned precast concrete beam or cast-in-situ. Columns are construed continuously through joints and beams as single bay. This standard states the frame as hybrid frame due to the condition that the frame combines ordinary reinforced concrete construction that is designed to yield while the unbonded post-tensioned tendon remains elastic during earthquake.

This paper presents ACI 550.3-13 concept, the example of system design conforming to the concept, verification testing, of first example, i.e., Tamansari Hive Office Building in Jakarta, Indonesia in 2014, which eventually repeated in the design of apartments, landed houses and hospitals.

### **2. ACI 550.3-13 Concept**

In this type of hybrid frame there exist to main components. The first component is unbonded post-tensioned tendon. The second component is energy

dissipator made of horizontal bar grouted in a hose and placed inside column at upper and lower face of beam. This second component also provides additional continuity between beam and column and provides additional beam moment resistant. The bars dissipate energy through yielding in alternate tension and compression during earthquake.

The key feature of this system is that the bars are freely grouted and the bond is removed at certain distance inside beam at beam-column connection to reduce highly cyclic strain, if otherwise would occur at that location. As consequence, during earthquake the beams and columns undergo rigid body motion with deformation particularly occurs at beam-column connection.

The second feature is the fact that post-tensioned tendon allows beam to be built without permanent corbel usually used in precast concrete construction. Post-tensioned tendon has two functions. First, friction induced by post-tensioned transfers vertical shear at beam-column connection for gravity and lateral loads. Secondly, with post-tensioned tendon strictly designed to remain elastic in design

earthquake occurrence, post-tensioned tendon forces the moment frame to return to initial position after designed earthquake.

Under seismic load, special moment frame mentioned in this standard has behaviour different from monolithic frame. Most of deformation of frame occurs due to opening and closing of joints at contact surface of precast beam and column. Therefore, with detailing procedure describe in this standard, existence of damage during severe earthquake is essentially limited on joint filler material and the damage may be repaired after earthquake occurrence. In contrast, monolithic frame designed according to Article 21 ACI 318-11 (SNI 2847:2013) may suffer significant cracks and melepuk at beam plastic hinges, at beam-column joints or at both, and the repairment may be highly costly. Further, monolithic special moment frame designed according to Article 21 ACI 318-11 (SNI 2847:2013) may demonstrate permanent lateral deformation after designed earthquake, while special moment resistant frame discussed in this standard does not experience permanent lateral deformation.

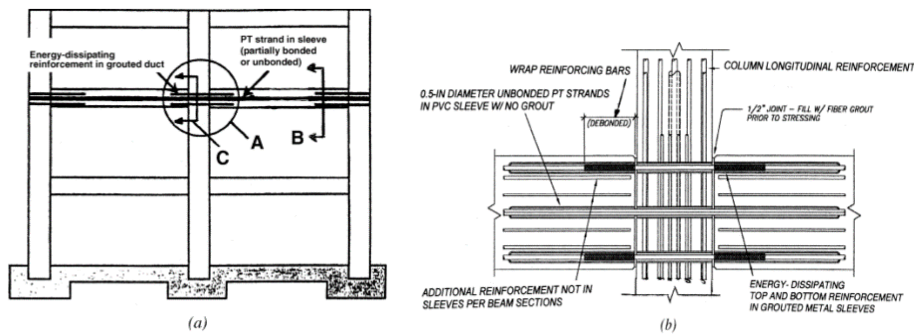

Figure 1. Typical moment frame composed from discretely jointed precast concrete members (a) elevation of typical interior moment frame; (b) detail of connection-A [1]

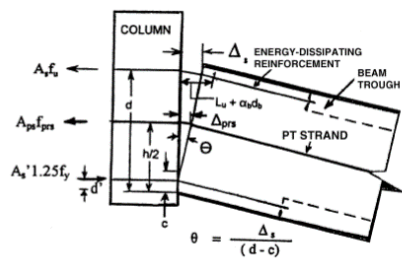

Figure 2. Rotation at beam-column interface [1]

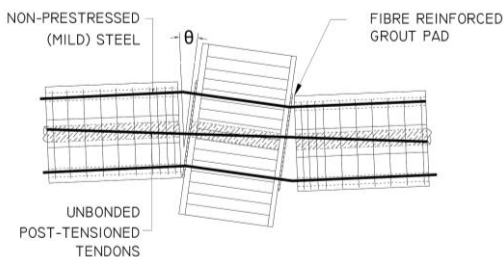

Figure 3. Pos-tensioned Tendon and recentering effect [11]

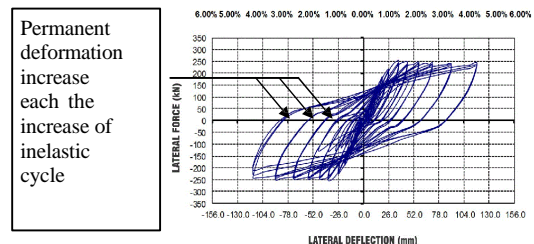
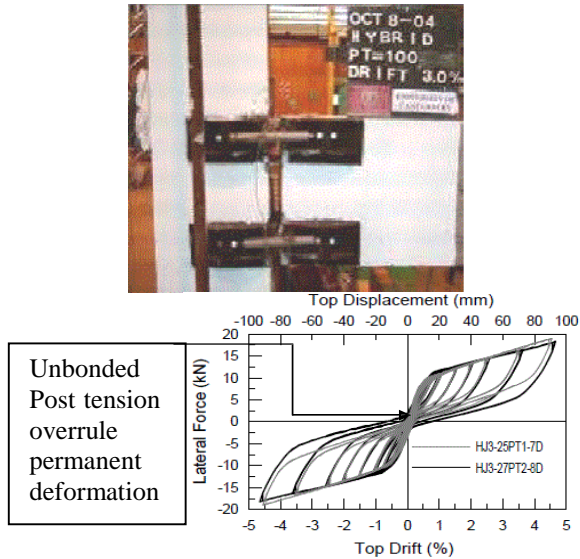

Figure 4. Behaviour of Monolithic Special Moment Resistant Frame According Article 21 ACI 318-11(SNI 2847:2013) [13]



**Figure 5.** Behaviour of Unbonded Post-tensioned Special Moment Resistant Frame [12]

Several requirements in ACI 550.3-13, among others are as follows.

1. Conversion of main beam reinforcement from mild steel to hybrid reinforcement (combination of mild steel and prestressed steel). Maximum ratio of mild steel moment capacity  $M_s$  to possible moment capacity  $M_{pr}$  according to Article 4.2

$$M_s / M_{pr} \leq 0.5 \quad (1)$$

2. Prestressing steel used is high quality steel according to standard ASTM A416 Grade 270, Article 4.4.2.
3. Dissipating energy reinforcement must meet requirements ASTM A 706/A706M Grade 60 [2], Article 4.3.1.
4. Minimum prestressing steel in Article 7.2.1,

$$A_{ps} f_{se} = \frac{(1.2V_D + 1.6V_L)}{\phi \mu} \quad (2)$$

in which  $A_{ps}$  is prestressing steel area,  $f_{se}$  is effective stress in post-tensioned tendon,  $\mu$  is friction coefficient 0.6 in magnitude,  $V_D$  shear force due to unfactored dead load,  $V_L$  shear force due to unfactored live load and  $\phi$  is shear reduction factor.

5. Energy dissipator bar minimum cross section area, according to Article 7.4.1,

$$A_s f_y \leq \frac{V_D + V_L}{\phi} \quad (3)$$

in which  $A_s$  is mild steel area,  $f_y$  mild steel yielding stress,  $V_D$  shear force due to unfactored live load, and  $\phi$  is shear reduction factor.

6. The design of joints is carried out considering beam capacity moment which causes ultimate tension force in mild steel as well in prestressing steel as shown in Figure 6. Care must be paid to the use of special strength reduction factor in Particle 21.7.4.1 ACI 318-11 (SNI 2847:2013),  $\phi = 0.9$ .

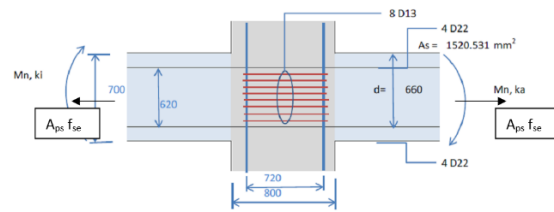

**Figure 6.** Internal Forces in Joint Capacity Condition Design

### 3. System Design Example

The development achieved in Indonesia is based on existing material and technology [9]. Unbonded post-tensioned concept are relatively well recognized in Indonesia so that materials, equipments and construction method are not problematic. Continuous precast column components made in high single unit may be handled with heavy equipment. Beam component is then positioned using unbonded post-tensioned tendon as depicted in Figure 7.

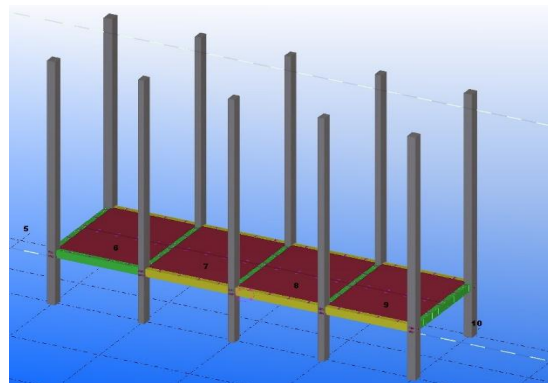

**Figure 7.** Example of System Development in Indonesia: Unbonded Post-tensioned Tendon

Dissipation energy concept is developed from reinforcement splice technology made of spiral reinforcement as shown in Figure 8a. This equipment is placed within the beam as in Figure 8b. This design is very unique as combination of internal and external energy dissipation concept. This equipment is hidden inside structure, but it may be repaired in ease if damaged by strong earthquake.

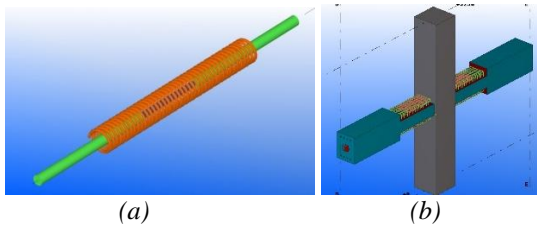

Figure 8. Energy Dissipation Concept Based on Local Material and Technology

Several detail concepts in this system merely as complements. At beam-column connection, support is construed as corbel, functioning as beam support at construction stage and providing additional shear resistant for beam contributed by prestressing force as shown in Figure 9. With this concept, the need of using scaffolding is avoidable.

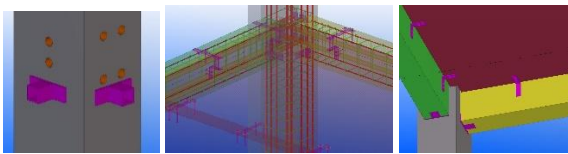

Figure 9a. Design of Small Steel Corbel

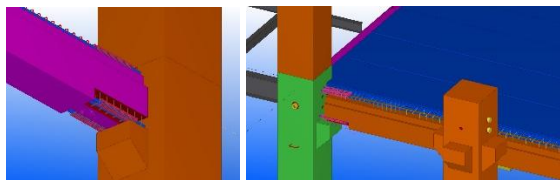

Figure 9b. Design of Permanent Concrete Corbel

Slab components in this system may be construed as two-way slab, or as hollow core one-way slab. If topping is used, then the slab system may behave as rigid diaphragm. If topping is not used on hollow core one-way slab, then several joints are needed to sustain load in diaphragm in earthquake occurrence [6,7] as shown in Figure 10. This type of one-way slab may behave as semi rigid diaphragm.

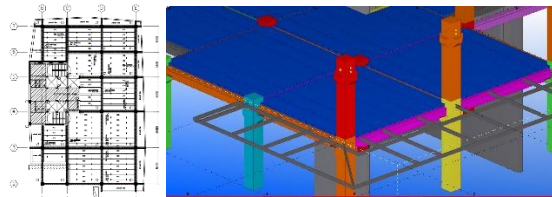

Figure 10. Slab System Component Concept Developed in Indonesia

#### 4. The Testing of System

The development and testing of the system were carried out in 2013-2014 [9,10] as shown in Figure 11, and the works were continued in 2016. The testing were carried out according to ACI 374.1-05 (SNI 2847-2012) as shown in Figure 12 [10], in which specimens met requirements in strength, stiffness and energy dissipation until maximum drift 3.5%. Figures 13 and 14 demonstrate the testing results of interior and exterior joints, and the results show that the

system behave elastically until drift 1%, and then behave post elastic and recentering until drift 2.2%, with rigid body rotation occurring at joint location energy dissipator steel according to the design.

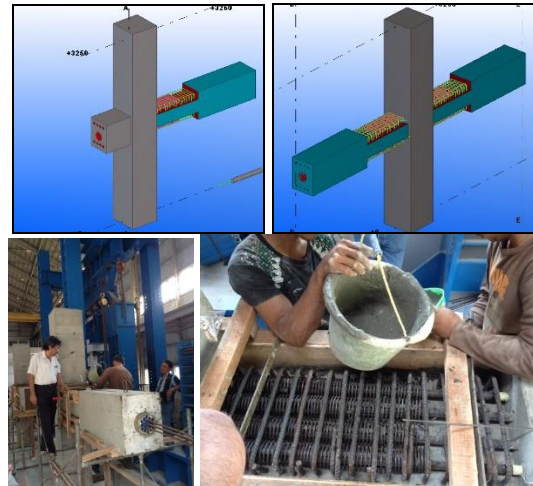
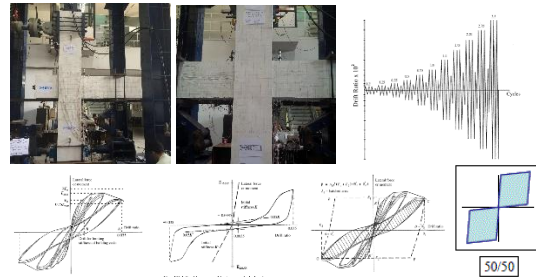
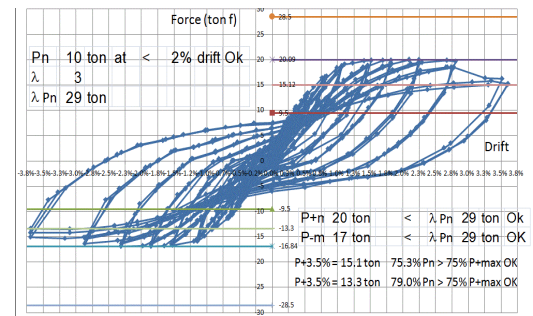

Figure 11. Specimens



(a) Requirements in ACI 374.1-05



(b) Inspection of Strength Condition

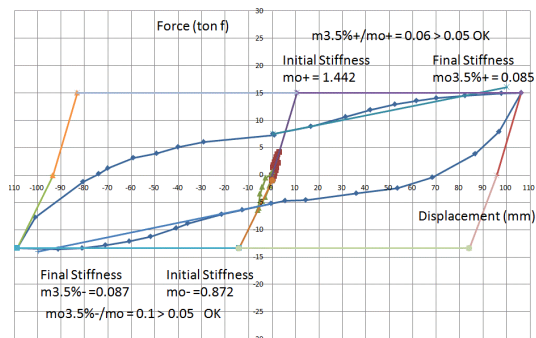

(c) Inspection of Stiffness Condition

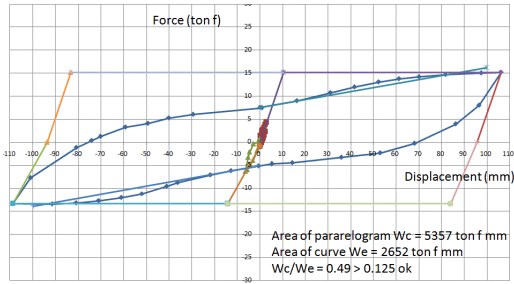

(d) Inspection of Energy Dissipation Condition

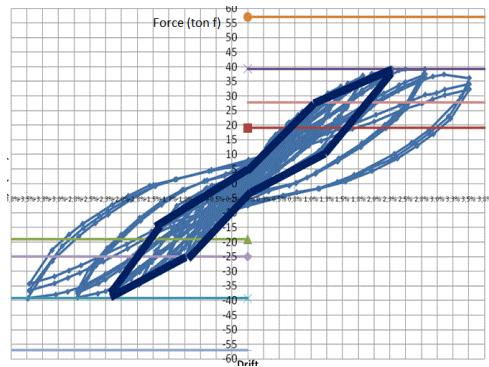

(e) Recentering Behaviour Until drift 2.2%

Figure 12. Testing of Beam-Column Joint According to ACI 374.1-05 (SNI 7834-2012) [4,10]



(a) Drift at 1% (b) Drift Until 2.2%+

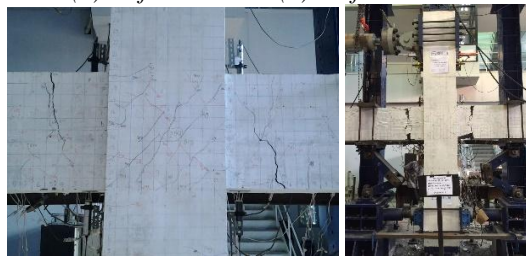

(c) Drift Until 2.2%- (d) Drift at 3.5%

Figure 13. Testing Result, Interior Joint



(a) Drift at 1% (b) Drift Until 1.4%



(a) Drift at 1.75% (b) Drift at 3.5%

Figure 14. Testing Result, Exterior Joint

5. Example of Applications

This kind of system is applied to 12-storey Tamansari Office Hive shown in Figure 15 (2015).



Figure 15. Twelve storey Tamansari Office Hive (2015)

This building is of twelve storey and three basements. Upper structure frame uses precast column, beam and hollow core slab components, while basement and shear wall components are made of cast-in-situ concrete. In this first application project, construction method was chosen without scaffolding so that the construction was carried out in faster fashion.

As addition, beam-column connection uses energy dissipation concept and column-column connection uses grouted splice sleeve. Diaphragm components are made of hollow core slab, behaving as one-way slab. This component was designed such that it may provide rigid or semi rigid diaphragm effect.

The system was then applied in 2015 to six storey apartment building as shown in Figure 16. Some variations were performed to conserve splice sleeve joints and temporary corbel.



Figure 16. Six-storey Apartment in Jakarta (2015)

The system also applied in 2015 to three-storey apartment as shown in Figure 17. Variations carried out are the use of three-storey column single unit to conserve the use of splice sleeve joint, and conserve the use of scaffolding in beam construction to avoid provision of corbels at columns.



**Figure 17.** Three-storey Apartment in Pandeglang, Cipulir, Cijantung, and Serpong (2015)

The system also applied in 2015 to landed houses as shown in Figure 18. With all components are made of pre-fabricated units, 36 m<sup>2</sup> type of landed houses may be constructed completely in 18 hours.



**Figure 18.** Landed Houses Constructed in 18 Hours (2015)

Different variations applied in 2016 to apartments in Sumatera Island is shown in Figure 19. Slab uses reinforced concrete since hollow core products are not available. Construction was carried out using limited scaffolding in beams and slabs so that corbels are not needed at columns.



**Figure 19.** Three-storey Building at Natuna, Nias, Rokan Hilir and Banyuasin (2016)

Other variations using short corbel made of hollow steel box were applied in 2016 to Purwakarta store as shown in Figure 20. The corbels eventually are hidden within beam-column joints. The slabs are made of reinforced concrete and the construction was carried out using limited scaffolding on beams and slabs.



**Figure 20.** Three-storey Store in Purwakarta (2016)

Another variation was applied in 2017 to eight-storey and 3 basements hospital in Jakarta as in Figure 21. In precast column components, hat shape corbels were provided at upper locations. These corbels function as precast beam support. Precast beams have shell shape at both end. Joint reinforcement and energy dissipator

were then installed and grouted. Column components of next storey were then connected with splice sleeves. Slab components were made as hollow core units.



**Figure 21.** Eight-storey and three basement Hospital in Jakarta (2017)

## 6. Conclusions

High rise buildings are main component in city infrastructure, due to high price land and limited of space. In accordance with infrastructure construction acceleration in Indonesia nowadays, arises necessity to provide system and method of construction that beside conforming to reliability in earthquake resistant, also securing quality, speed and ease of construction.

Since 2012 (SNI 1726:2012) Indonesia has adopted new design concept based on American code (ASCE 7-10) [3] that requires performance higher than previous code (SNI 03-1726-2002) based on UBC 1997. One influence of performance requirements is that special moment resistant frame has to be categorized as D, E and F design seismic category, generally confronted in large cities in Indonesia. This change causes increase in construction cost and requires strict supervision.

Precast system is an alternative construction system that may be carried out faster with better quality control. In earthquake reliability, SNI 7833-2012 (adopted from ACI 318-08) provides an alternative in unbonded post-tensioned precast special moment resistant frame as described in Article 7.8.4 (Chapter Commentary ACI 318-08), mentioning that the base of the system is ACI ITG 1.2: Special Hybrid Moment frames Composed of Discretely Jointed Precast and Posttensioned Members. In 2015, Pusat Penelitian dan Pengembangan Permukiman Kementerian Pekerjaan Umum dan Perumahan Rakyat issued Indonesian Code concerning this system based on an updated version of ACI ITG 1.2, i.e., ACI 550.3-13 Design Specification for Unbonded Post-tensioned Precast Concrete Special Moment Resisting frame Satisfying ACI 374.1 (ACI 550.3-13) and Commentary. The draft was agreed upon in October 2015 and legalized by Panitia Penetapan SNI Badan Penelitian dan Pengembangan Kementerian PU PR, which sanctioned by Badan Standard Nasional Indonesia in 2016.

Precast and prestressed concrete industry in Indonesia has developed precast system based on ACI 550.3-13 since 2013 using local material and technology. The system has been applied to several office buildings, apartments, stores, landed houses and hospitals in several varieties in details and methods of construction so that it lends itself to acceleration of construction of high rise buildings in Indonesia.

## References

- [1] American Concrete Institute, *ACI 550.3-13 Design Specification for Unbonded Post-Tensioned Precast Concrete Special Moment frame Satisfying ACI 374.1 and Commentary*, Farmington Hills, 2013.
- [2] American Standard of Testing Material, *ASTM A706/A706M-14 Standard Specification for Deformed and Plain Low-Alloy Steel Bars for Concrete Reinforcement*, West Conshohocken, 2014.
- [3] American Society of Civil Engineers, *ASCE/SEI 7-10 Minimum Design loads for Buildings and Other Structures*, ASCE, 2010.
- [4] American Concrete Institute, *ACI 374.1-05 Acceptance Criteria for Moment Frames Based on Structural Testing and Commentary*, Farmington Hills, 2013.
- [5] American Concrete Institute, *ACI 318-11 Building Code Requirements for Structural Concrete (ACI 318-11) and Commentary*, Farmington Hills, 2011.
- [6] B. Budiono, "Seismic Design Recommendation of Special Moment Frame with Hollow Core Slab (HCS) Constructed using WIKA BETON Precast Technology", *Conference on WIKA BETON GEDUNG KAVLING 2-2014*, PT Wijaya Karya Beton, 2014.
- [7] R.B. Fleischman, *Seismic Design Methodology Document for Precast Concrete Diaphragms*, Charles Pankow Foundation, 2014
- [8] F. Naeim, and R.R. Boppana, "Seismic Design of Floor Diaphragm", *Seismic Design Handbook*, ICBO, 1995
- [9] H.N. Nurjaman, L.Faisal, H.R. Sidjabat, B. Hariandja, Y. Put, and R.Rivky, "Application of Precast System Building with using Connections of Unbonded Post-Tension and Local Dissipater Device ", *Elsevier Procedia Engineering Journal*, Volume No.95. Issue No. 82-88.,2014.
- [10] H.N. Nurjaman, L.Faisal, H.R. Sidjabat, B. Hariandja, Y. Put, and R.Rivky, "Research, Design and Application of High Performance Earthquake Resistant Precast Structure in Indonesia", *16<sup>th</sup> World Conference on Earthquake Engineering-2017*, PP 0525, 2017.
- [11] S.Pampanin, *PRESSS Design Handbook*, New Zealand Concrete Society, 2010
- [12] S.Pampanin, "Reality-check and Renewed challenges in Earthquake Engineering : Implementing low-damaged structural system – from theory to practise", *15<sup>th</sup> World Conference on Earthquake Engineering-2012*, PP Keynote speech, 2012.
- [13] S.Yuwasdiki, "Prosedur Pendaftaran dan Penerimaan Sertifikasi Sistem Pracetak Beton di puslitbang Permukiman Kementerian Pekerjaan Umum", *Sosialisasi SNI Gempa dan Konstruksi Pracetak dan Prategang untuk Bangunan Gedung*, Kementerian Pekerjaan Umum -IAPPI, 2013