

# Design Mobile Application Variable Temperature and Humidity Water Flow Rate Automatic Control System

*by* Sularso Budilaksono

---

**Submission date:** 08-Jun-2023 02:41PM (UTC+0700)

**Submission ID:** 2111613283





**File name:** rature\_and\_Humidity\_Water\_Flow\_Rate\_Automatic\_Control\_System.pdf (1,006.83K)

**Word count:** 4914

**Character count:** 23727



# Design Mobile Application Variable Temperature and Humidity Water Flow Rate Automatic Control System

Nizirwan Anwar<sup>1</sup>✉ , Agung Mulyo Widodo<sup>1</sup> , Mosiur Rahaman<sup>2</sup>,  
Sularso Budilaksono<sup>3</sup> , Roesfiansjah Rasjidin<sup>1</sup> , Hendry Gunawan<sup>1</sup>,  
Kundang Karsono Juman<sup>1</sup>, and Muhammad Abdullah Hadi<sup>1</sup> 

<sup>1</sup> Esa Unggul University, Jakarta 11510, Indonesia  
(nizirwan.anwar, agung.mulyo, roesfiansjah.rasjidin,  
hendry.gunawan, kundang.karsono)@esaunggul.ac.id,  
muhammad.abdlhadi@student.esaunggul.ac.id

<sup>2</sup> Asia University, Taicung 413, Taiwan  
mosiurrahaman@asia.edu.tw

<sup>3</sup> YAI Persada Indonesia University, Jakarta 10430, Indonesia  
sularso@upi-yai.ac.id

**Abstract.** The primary measurements used to calculate the amount of water required are soil temperature and plant humidity. As a result of this system's sophisticated functional equations and non-linear input design, it needs a system that can decide when to sprinkle water. One of the ideas that can be applied to produce a judgment that is similar to the ones made by people is fuzzy logic. Used was a microcontroller-based fuzzy logic control system. The goal of this is to create a method for managing the amount of water and fertilizer that plants receive. Temperature and soil surface moisture measurements are measured by this system using the DHT11 sensor. Additionally, this system controls with fuzzy logic using a pH sensor as an input. In addition to real-time information and reports, this system may be watched over utilizing a mobile application. The Blynk Node MCU ESP8266 microcontroller's built-in Wi-Fi module is a great option. The average connection speed between the first and second pumps is 1235.90 ms, with a linear correlation of 0.6754 and a Pearson correlation of 0.7158. During physical activity, core body temperature rises as relative humidity rises, and falls as humidity falls.

**Keywords:** Mobile Application · Temperature · Humidity · Flow Rate · Control System

## 1 Introduction

Watering is a repetitive task that is performed frequently, whether at home, in the garden, along sidewalks, or with cultivated plants. Paying specific employees or workers to water the plant at specific times is a standard procedure. The water supply problem is the most

© The Author(s) 2022

I G. P. Suta Wijaya et al. (Eds.): MIMSE-I-C 2022, ACSR 102, pp. 326–340, 2022.

[https://doi.org/10.2991/978-94-6463-084-8\\_28](https://doi.org/10.2991/978-94-6463-084-8_28)

serious issue. How much water should be removed from the plants you intend to water so that water is not wasted and water is not wasted?

A mediocre control system is insufficient for plant monitoring because it can only adjust when the water pump is activated without observing and evaluating the condition of the soil surrounding the plant. Despite the fact that the task at hand may be more complex. According to research [1], the daily water demand in Temanggung Subdistrict is 96.21 L per person 79,234 people = 7,623,103.14 L per day. 49.25% of 67 samples indicate that one person consumes between 83.81 and 107.60 L of water in a single day. Those exceeding the standard range from 107.67 to 131.40 L per person per day, with a percentage of 22.39%. With this system, it is hoped that the amount of water used for watering plants will be reduced from 5.40 to 10.01 L per person per day, or approximately 7.22% of the average water consumption in the region. Thus, a special control system is required. To account for this, a Fuzzy Logic-based method will be utilized, which has three (three) main parameters: temperature, humidity, and pH [2]. This system is intended to regulate the amount of water required to water these plants. Due to this, this study refers to a plant water management system that can be monitored anywhere and at any time [3], which does not require a great deal of time, so we can still carry out more important tasks and have a gardening hobby with healthy plant results and no fertilizer shortage. This system employs a mobile phone to monitor data transmitted over the Internet; naturally, the mobile phone must have a monitoring application installed. This specific application is called Blynk. Blynk is a mobile application platform [4], compatible with IOS and Android, that enables Internet-based control of microcontroller modules and similar devices [5]. This application is a platform for creating drag-and-drop widget-based user interfaces for projects that users wish to develop. Everything is simple to configure and can be done in a short amount of time. Blynk is not dependent on a specific system [6, 7].

This application can control or monitor anything, regardless of location. This system must be connected to the internet, and it is referred to as the IoT system [8, 9]. The microcontroller can read the DHT11 sensor and pH sensor [10] to obtain temperature, humidity, and pH input values. The microcontroller uses fuzzy logic to determine whether it is necessary to turn on the pump in order to process the data; the output of the processing is sensor data and pump status, which is then transmitted over the internet to Blynk Cloud. Earlier research indicated that mechanical devices that are controlled by electronic equipment could make watering plants easier. This system is a control device that can automatically adjust the amount of water given to plants based on soil moisture and air humidity levels. Arduino Uno is connected to soil moisture and DHT11 [6, 11] as an adjustment for watering the plants between 10:00 and 14:00 WIB. The primary function of the primary component of this automation tool is to store control circuits. The second component is a water line equipped with an opening and closing water solenoid valve.

## 2 Methodology

The method used when conducting this research [12] is the prototyping method. Prototyping is a system development and development technique that uses a prototype first to describe the system to be developed so that researchers have an overview of the system

to be built and developed. With prototyping techniques, developers can make a prototype first before developing the actual system, and the method used to analyze this problem is the PIECES method [13]. There are 2 (two) types of techniques used in data collection, namely observation,

then the delimiter becomes the following equation:

$$w \cdot x_i + b \leq -1 \quad (1)$$

If the data label is  $y_i = +1$ , then the delimiter becomes the following equation:

$$w \cdot x_i + b \geq +1 \quad (2)$$

The largest margin can be found by maximizing the distance between the boundary planes of the two classes and their closest point, which is  $\frac{2}{|w|}$ . This is formulated as a Quadratic Programming (QP) problem, in which the goal is to identify the equation's minimum point by taking into account the following equation:

$$L(w, b, a) = \frac{1}{2} \|w\|^2 - \sum_{i=1}^n a_i (y_i (w^T x_i + b) - 1) \quad (3)$$

$$L(w, b, a) = \frac{1}{2} \|w\|^2 - \sum_{i=1}^n a_i y_i (w^T x_i + b) + \sum_{i=1}^n a_i \quad (4)$$

where  $a_i$  is the lagrange multiplier which is zero or positive ( $a_i \geq 0$ ). The optimal value from the previous equation can be calculated by minimizing  $L$  to  $w$ ,  $b$  and  $a$  can be seen in the following equation:

$$\frac{\partial L}{\partial a} = \sum_{i=1}^n a_i y_i (w^T x_i + b) - \sum_{i=1}^n a_i = 0 \quad (5)$$

## 2.1 Kernel Trick

SVM can be extended to draw a non-linear decision boundary by transforming the input from the original space to a high-dimensional space. Since the relationship between the input space and the transformation space is non-linear, the goal is to obtain a non-linear decision boundary [13, 14]. To improve the accuracy of the problem, SVM has a kernel trick that can help solve the problem of changing data into non-linear space. In general, some of the most commonly used kernel functions in SVM are as follows [13, 14]:

$$\text{Linear Kernel } K(X_i, X_j) = X_i^T \cdot X_j$$

$$\text{Polynomial Kernel } K(X_i, X_j) = (X_i \cdot X_j + 1)^h$$

$$\text{RBF } K(X_i, X_j) = e^{-\|X_i - X_j\|^2 / 2\sigma^2}$$

$$\text{Sigmoid } K(X_i, X_j) = \tanh(kX_i \cdot X_j - \delta)$$

## 2.2 Python Programming Language

A identification or classification system must be capable to correctly classify all data sets in order to operate. However, it is impossible to disputed that a system's performance, that performs classification will not always be 100% correct. Therefore, the system performance must be measured. Generally, the way to measure classification performance is using a confusion matrix [13, 15]. Measurement of the effectiveness of a classification system is crucial. The system's performance is described using a performance classification system in classifying data. One technique for evaluating a classification method's performance is the confusion matrix. The confusion matrix essentially provides data that contrasts the system's classification results with those of the classification that should be [13]. There are 4 (four) terms used to represent the outcomes of the categorization process when performance is measured using a confusion matrix. True Positive (TP), True Negative (TN), False Positive (FP), and False Negative are the four terms (FN). The number of negative data that are accurately recognized is known as the True Negative (TN) value, while false positives (FP) are instances of negative data that are mistakenly identified as positive. True Positive (TP), however, refers to positive data that has been accurately detected. The reverse of true positive, false negative (FN), refers to data that is positive but is mistakenly identified as negative. Accuracy values can be determined based on the values of True Negative (TN), False Positive (FP), False Negative (FN), and True Positive (TP). How accurately the system can correctly classify the data is shown by the accuracy value. In other words, the accuracy value compares the correctly classified data to the entire set of data. The precision value can be obtained by the equation below.

$$\text{Accuracy} = \frac{TP + TN}{TP + TN + FP + FN} \quad (6)$$

Precision. It gauges true positive predictions. Equation 6 is used to calculate a model's precision:

$$\text{Precision} = \frac{TP}{TP + FP} \quad (7)$$

A sensitivity measure is this one. It is developed to evaluate how well a model predicts positive labels. It is determined by applying Eq. 7:

$$\text{Recall} = \frac{TP}{TP + FN} \quad (8)$$

F-Measure. Recall and precision (Eq. 8) are also considered in this metric. It can be thought of as a weighted average of recall and precision metrics, with values ranging from 0 (worst) to 1 (best). Equation 9. is used to calculate the F-measure.

$$F - \text{Measure} = 2 \times \frac{\text{Precision} \times \text{Recall}}{\text{Precision} + \text{Recall}} \quad (9)$$

### 3 Result and Discussion

#### 3.1 Proposed System Design

Based on the results of the problem analysis described using PIECES analysis [9], the writer will make a problem-solving solution plan, namely creating a system that can regulate the amount of water in plants automatically based on temperature and humidity input. The solution to the problem proposed by the author is to create a Water Amount Regulating System Based on Temperature and Humidity Based on a Mobile Application [14], which will facilitate the human task of watering plants.

#### 3.2 Proposed System Design

This system uses a mobile phone device that has the Blynk application installed and connected to the internet to communicate with the microcontroller so that it can be controlled and monitored remotely. The information obtained by the Blynk application is in the form of data on temperature values and humidity values obtained from the DHT 11 sensor and also pH value data from the pH sensor and history of the relay that is connected to the water pump. This system uses 1 (one) 2 (two) channel relay to accommodate 2 (two) water pumps because the first water pump is shown for water and the second is for fertilizer in liquid form. The Data is processed via a microcontroller connected to the internet.

#### 3.3 Proposed System Design

The way these tools works is started with a microcontroller Node MCU ESP8266 [15, 16], which checks whether it is connected to the internet, after which it will send an authentication code to Blynk Cloud via the internet. If so, the system will start reading the DHT11 sensor and pH sensor. After obtaining the desired data in the form of temperature, humidity, and pH values, the system will process the data and determine with fuzzy logic whether the water pump and liquid fertilizer need to be turned on or not. Then the system will record the time (date and time) and the pump status after the Data is processed. After that, the microcontroller will again check whether it is still connected to the internet or not; if so, sensor data, pump status, and processing time will be sent to Blynk Cloud via the internet (Figs. 1 and 2).

#### 3.4 Proposed System Design

The Unified Modeling Language (UML) is a general-purpose, developmental, modeling language in the field of software engineering that is intended to provide a standard way to visualize the design of a system [16–18]. The creation of UML was originally motivated by the desire to standardize the disparate notational systems and approaches to software design. It was developed at Rational Software in 1994–1995, with further development led by them through 1996. In 1997, UML was adopted as a standard by the Object Management Group (OMG), and has been managed by this organization ever since. In 2005, UML was also published by the International Organization for



Fig. 1. System Design Schematic



Fig. 2. Schematic of How the Tool Works

Standardization (ISO) [19] as an approved ISO standard. Since then the standard has been periodically revised to cover the latest revision of UML In software engineering, most practitioners do not use UML, but instead produce informal hand drawn diagrams; these diagrams, however, often include elements from UML direct observation is made of a plantation area or public facilities where there are many plants, and literature study [20] where literature studies are carried out to find and get information sources, and to

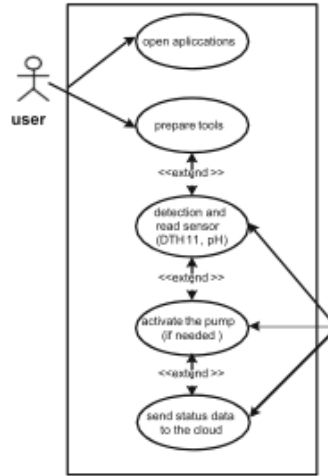

Fig. 3. System Design Schematic

Table 1. Define Actor

Number	Actor	Descriptions
1	User	The user acts as a user actor or owner of a mobile phone that uses the application.
2	System	Acting as an actor who processes logic and responds to the system.

get a theoretical basis that supports the data and information obtained as a reference in planning, conducting experiments, making processes, and compiling research reports

- Use Case Diagram (Fig. 3, Tables 1 and 2)
- Activity Diagram

In this activity, interaction occurs between the user, system, and Cloud Blynk. Starting with the user who opens the Blynk application contained in the mobile phone, then the user will turn on the device by entering the 12 V adapter into the electricity source. Then after the tool turns on, the system will start reading the DHT11 sensor [21] and pH sensor to get temperature, humidity, and pH values so that the system can process it using a fuzzy algorithm to determine whether the water pump and liquid fertilizer pump need to be turned on or not. Then after getting the temperature, humidity, pH, and status values of the two pumps, the system will send the data to the Cloud via the internet. After the Data is received by the Blynk Cloud, the data will be sent back to the user via the internet so that all the data can be displayed in the Blynk application (Fig. 4).

- Activity Diagram (Fig. 5)
- Component Diagram (Fig. 6)
- Deployment Diagram (Fig. 7).



**Table 2.** Define Use Caser

Number's	Use Case	Descriptions
1	Open the Application	Users can open the Blynk application to monitor tools and view pump usage records.
2	Turn on the Tool	Users can turn on the appliance by inserting the 12 V adapter into a power source.
3	Reads DHT11 Sensor and pH Sensor	The system will start reading data from the DHT11 sensor and pH sensor to get temperature, humidity and pH values.
4	Starting the Pump (If Required)	The system will process data based on input parameters in the previous stage and provide a decision whether the pump needs to be started or not.
5	Sending Data to the Cloud	The system will send data on temperature, humidity, pH, pump status, and time when the data is processed.

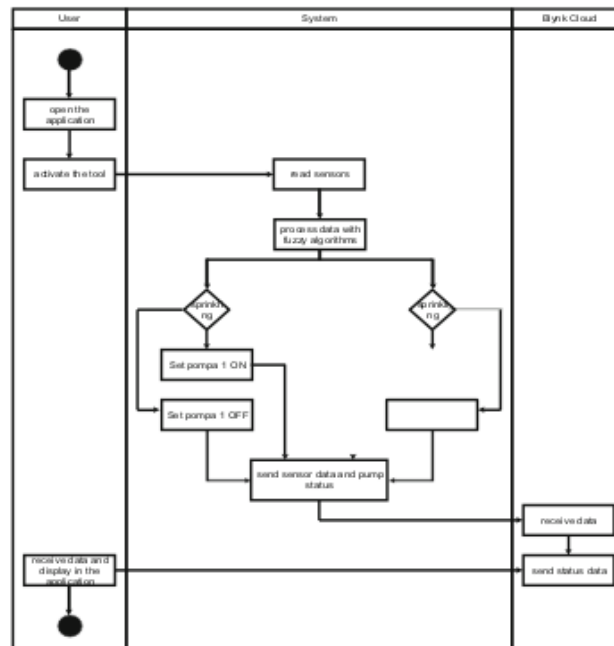

**Fig. 4.** Activity Diagram

Implementation is done by connecting all system nodes that have been created and linked together so that it becomes a complex system. Figure 9 describes all the components that are connected. For the first stage, after all components are connected, the next step is to connect Node MCU to a laptop using a USB cable to upload code to Node MCU. After that, open the Arduino IDE on the laptop and press the upload button and wait for the loading to finish. After loading is complete, unplug the USB cable and

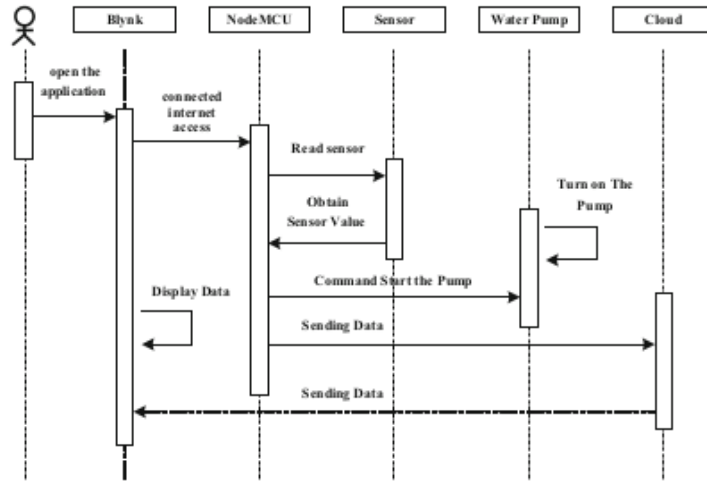

Fig. 5. Sequence Diagram

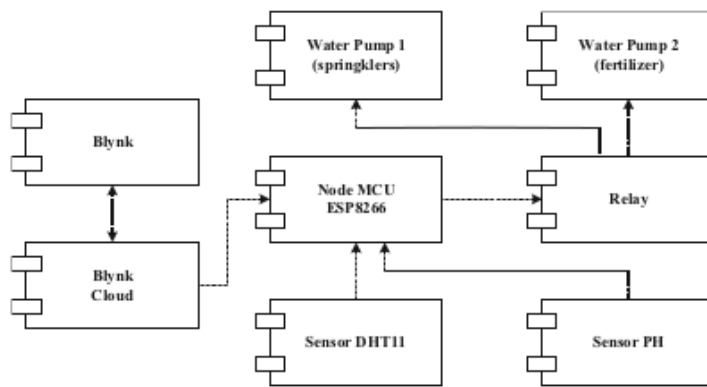

Fig. 6. Components Diagram

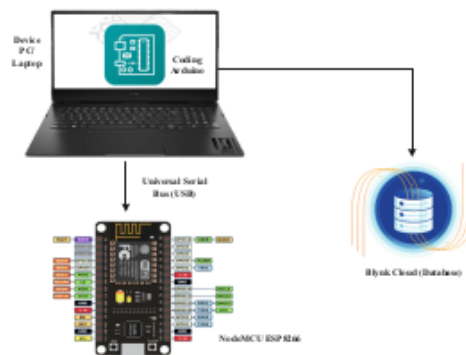

Fig. 7. Deployment Diagram

connect the 12 V adapter to Node MCU and the power source. After that, the system is ready to use. This stage is only the first time the system is implemented. In the future, we only need to connect the 12 V adapter to a power source.

**Table 3.** Sensor Testing

Numbers	Time	Temperature	Humidity	pH
1	06:00	30	65	7
2	08:00	30	68	7
3	10:00	32	77	7
4	12:00	34	83	7
5	14:00	33	81	7
6	16:00	32	77	7
7	18:00	31	79	7
8	20:00	31	80	7
9	22:00	30	78	7
10	00:00	30	76	7

### 3.5 Testing

Testing of this system is done by turning on several sensors installed on the Node MCU microcontroller according to the function of the sensor to be tested. Testing on the DHT11 sensor is a reading test carried out by the DHT11 sensor module, which is connected to the Node MCU ESP 8266 microcontroller to read the temperature and humidity values around the plant scope. Testing of all these sensors is not intended to measure the accuracy of sensor readings because the output on these sensors is calibrated at the time of purchase (Table 3).

The test results of the two sensors show the results of the DHT11 and pH sensor readings [22]. The test results on the DHT11 sensor and pH sensor show that the sensor can read the temperature, humidity, and pH values, which will later be sent to Blynk Cloud via the internet. Therefore, we will test the connection between the Node MCU microcontroller and the internet via Wi-Fi.

Seen in Table 4 shows that Node MCU ESP8266 can be connected to Blynk Cloud via the internet network. After the test, the latency to Blynk Cloud [23] was 1242, indicating that the reception and sending of data from Node MCU were very slow. This happened because the internet used was not good. Next is the automatic watering test phase. The test is carried out for 1 (one) day, from morning to night. The results can be seen in the following table.

As seen in Table 10, which shows the results of observations of automatic watering for 1 (one) day, the results were slightly different from what was planned, namely 3 (three) times a day, and the test results only showed 2 (two) days a day. And for fertilizers, do not do watering because, during that day, there has been no change in the pH value of the soil. These data are obtained through the mobile application.

**Table 4.** Connection Speed Test

Numbers	Time	Ping (ms)
1	06:00	1230
2	08:00	1270
3	10:00	1250
4	12:00	1280
5	14:00	1180
6	16:00	1095
7	18:00	1165
8	20:00	1225
9	22:00	1297
10	00:00	1367
Average Ping		1235.90

**Fig. 8.** Experimental Tool Design and Implementation

### 3.6 Results of Method Implementation

The logical process for turning on the pump to water plants using a fuzzy algorithm is influenced by several factors, one of which is the sensor itself, whether the sensor has been calibrated correctly or not, the sensor is still running well or not, and whether the sensor is blocked or not. Receiving data in mobile applications is also strongly influenced by several factors. The main one is the connection between the microcontroller with the Blynk Cloud and the Blynk Cloud with the mobile application. However, these factors can be overcome by placing the sensor in the right position and using a good ISP in the area (Fig. 8).

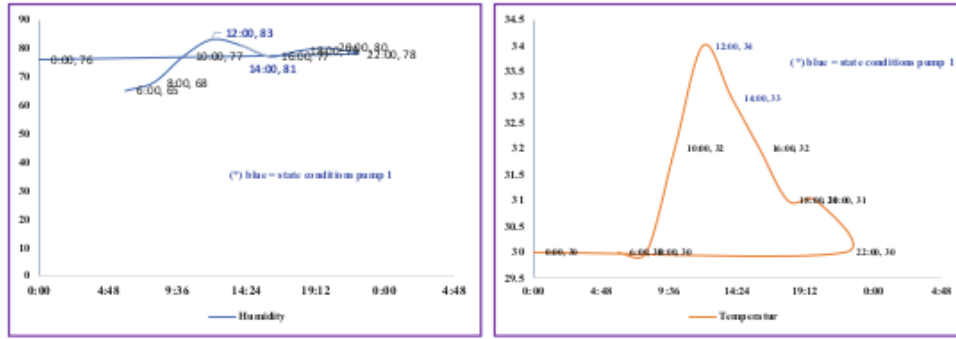

Fig. 9. Visualization of Humidity and Temperature Test Results (Pumps 1/2 Operating Simultaneously)

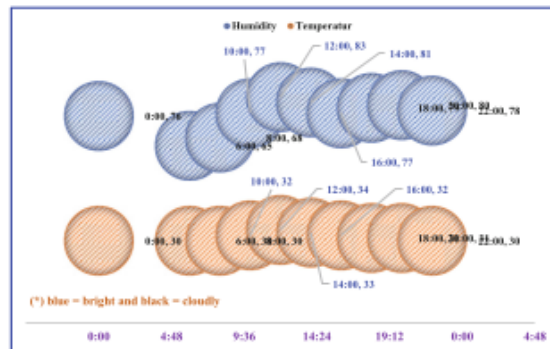

Fig. 10. Visualization Level of Humidity and Temperature Conditions (Cloudy/Bright)

All the parts that make up the whole can be seen in Fig. 9. Assuming you’ve already connected everything you need to, the first step is to plug the Node MCU into your laptop via USB so you can transfer the code to it. Then, once the download is finished, open the Arduino IDE on the laptop and push the upload button. To utilize the system, just disconnect the USB cable once loading is complete and plug in the 12 V adapter to the Node MCU and power supply (Fig. 10).

#### 4 Conclusion

Ten tests conducted between 6:00 a.m. and 12:00 a.m. showed that the first pump only runs twice during clear air conditions (at 2:00 p.m. and 4:00 p.m.). The second pump continues to run nonstop all day long (off). Data from Tables 5 and 6 reveal that the average connection speed between the first and second pumps is 1235.90 ms, with a linear correlation of 0.6754 and a Pearson correlation of 0.7158, respectively, when using the correlation approach. If you’re looking to connect your device to the internet so you can keep tabs on it in real time using the Blynk app, the Node MCU ESP8266 microcontroller’s built-in Wi-Fi module is a great option. During physical activity, core body temperature rises as relative humidity rises, and falls as humidity falls.

**Table 5.** Watering Testing Pump 1

Numbers	Time	Temperatur	Humidity	pH	Weather	1 <sup>st</sup> Pump
1	06:00	30	65	7	Cloudy	Off
2	08:00	30	68	7	Cloudy	Off
3	10:00	32	77	7	Bright	Off
4	12:00	34	83	7	Bright	On
5	14:00	33	81	7	Bright	On
6	16:00	32	77	7	Bright	Off
7	18:00	31	79	7	Cloudy	Off
8	20:00	31	80	7	Cloudy	Off
9	22:00	30	78	7	Cloudy	Off
10	00:00	30	76	7	Cloudy	Off

**Table 6.** Watering Testing Pump 2<sup>nd</sup>

Numbers	Time	Temperature	Humidity	pH	Weather	2 <sup>nd</sup> Pump
1	06:00	30	65	7	Cloudy	Off
2	08:00	30	68	7	Cloudy	Off
3	10:00	32	77	7	Bright	Off
4	12:00	34	83	7	Bright	Off
5	14:00	33	81	7	Bright	Off
6	16:00	32	77	7	Bright	Off
7	18:00	31	79	7	Cloudy	Off
8	20:00	31	80	7	Cloudy	Off
9	22:00	30	78	7	Cloudy	Off
10	00:00	30	76	7	Cloudy	Off

## References

1. N. A. Sistyanto and M. P. Hadi.: Penggunaan Air Domestik dan Willingness To Pay Air Bersih Pdam di Kecamatan Temanggung Kabupaten Temanggung. *Journal Bumi Indonesia* 1(3) (2012)
2. M. Eriyadi and S. Nugroho.: PROTOTIPE SISTEM PENYIRAM TANAMAN OTOMATIS BERBASIS SUHU UDARA DAN KELEMBABAN TANAH. (2018)
3. A. N. Abdullah.: Online Monitoring and Controlling Water Plant System Based on IoT Cloud Computing and Arduino Microcontroller. *Journal Engineering Science* 25(4), 1230–1240 (2017)
4. N. Patel and P. Patel.: Heart Attack Detection and Heart Rate Monitoring Using IoT. *Nehal Patel International Journal Innov. Adv. Comput. Sci.* 7(4), 611–615 (2018)

5. A. Asmawati, F. J. E. Putra, and L. Richie.: Control Led Through Internet Based on Nodemcu with Blynk Application. *Journal Aptisi Trans. Technopreneursh* 1(2), 170–179 (2019)
6. N. Mazalan.: Application of wireless internet in networking using NodeMCU and Blynk App. (2019)
7. I. H. Wayangkau, Y. Mekiuw, R. Rachmat, S. Suwarjono, and H. Hariyanto.: Utilization of IoT for soil moisture and temperature monitoring system for onion growth. *Journal Emerg. Sci.* 4(Special Issue), 102–115 (2020)
8. M. Mehta.: ESP8266 : A Breakthrough in Wireless Sensor Networks and Internet of Things. *International Journal Electron. Commun. Eng. Technol.* 6(8), 7–11 (2015)
9. J. Guth et al.: A Detailed Analysis of IoT Platform Architectures: Concepts, Similarities, and Differences. *Journal Internet of Things*, 81–101 (2017)
10. Y. A. Sihombing and S. Listiari.: Detection of air temperature, humidity and soil pH by using DHT22 and pH sensor based Arduino nano microcontroller. In: *AIP Conf. Proc.*, vol. 2221, p. 100008 (2020)
11. S. P. Dr.N.Shenbagavadivu.: IoT based multiple sensor (DHT11 , Soil moisture sensor) monitoring system. 6(2), 33–38 (2019)
12. P. Ajewole, F. Taiwo, and I. Oladipo.: Conceptual Framework of a Mobile App for Smart Farming (2021)
13. T. W. Simpson, J. R. Maier, and F. Mistree.: Product platform design: method and application. *Research in Engineering Design*, vol. 13, no. 1. Springer Science and Business Media LLC, pp. 2–22, 2001
14. L. García, L. Parra, J. M. Jimenez, J. Lloret, and P. Lorenz.: IoT-Based Smart Irrigation Systems: An Overview on the Recent Trends on Sensors and IoT Systems for Irrigation in Precision Agriculture. *Journal Sensors* 20(4), (2020)
15. S. Alone, O. Capstone, C. Model, and C. C.: Technical Reference ESP8266. pp. 1–22 (2006)
16. K. Matsumura, H. Mizutani, and M. Arai.: An Application of Structural Modeling to Software Requirements Analysis and Design. *IEEE Transactions on Software Engineering*, (4), 461–471 (1987)
17. N. Medvidovic, D. S. Rosenblum, D. F. Redmiles, and J. E. Robbins.: Modeling software architectures in the Unified Modeling Language. In: *ACM Transactions on Software Engineering and Methodology*, vol. 11, no. 1., pp. 2–57. (2002)
18. A. I. Wasserman.: Software engineering issues for mobile application development. In: *Proceedings of the FSE/SDP workshop on Future of software engineering research - FoSER '10*. ACM Press, (2010)
19. International Organization for Standardization and International Electrotechnical Commission.: Information technology - Open Distributed Processing - Unified Modeling Language (UML) Version 1.4.2. *Iso/Iec 19501:2005(E)*, vol. 4, no. 1, p. 454, (2005)
20. N. F. Anwar M. Dzulfiqar; Tjahjono, Budi; Ummanah, Ummanah; Febrianto, Haris; Malabay, Malabay.: PROTO-TYPING APLIKASI ANDROID KEMANFAATAN DALAM MENINGKATKAN ROYALTI PENULIS MEDIA EBOOK. *Journal Fokus Elektroda Energi List. Telekomun. Komputer, Elektron. dan Kendali* 5(3), 25–32 (2020)
21. G. M. Debele and X. Qian.: Automatic Room Temperature Control System Using Arduino UNO R3 and DHT11 Sensor. In: *2020 17th International Computer Conference on Wavelet Active Media Technology and Information Processing (ICCWAMTIP)*. IEEE, (2020)
22. H. Zunair, W. U. Hasan, K. T. Zaman, M. I. Haque, and S. S. Aoyon.: Design and Implementation of an IoT Based Monitoring System for Inland Vessels Using Multiple Sensors Network. (2018)
23. M. P. Sharma and M. Parveen Kantha.: Blynk' Cloud Server based Monitoring and Control using 'NodeMCU. *Int. Res. Journal Eng. Technol.* 7(10), 1362–1366 (2020)

**Open Access** This chapter is licensed under the terms of the Creative Commons Attribution-NonCommercial 4.0 International License (<http://creativecommons.org/licenses/by-nc/4.0/>), which permits any noncommercial use, sharing, adaptation, distribution and reproduction in any medium or format, as long as you give appropriate credit to the original author(s) and the source, provide a link to the Creative Commons license and indicate if changes were made.

The images or other third party material in this chapter are included in the chapter's Creative Commons license, unless indicated otherwise in a credit line to the material. If material is not included in the chapter's Creative Commons license and your intended use is not permitted by statutory regulation or exceeds the permitted use, you will need to obtain permission directly from the copyright holder.





# Design Mobile Application Variable Temperature and Humidity Water Flow Rate Automatic Control System

---

## ORIGINALITY REPORT

---

19%

SIMILARITY INDEX

15%

INTERNET SOURCES

15%

PUBLICATIONS

0%

STUDENT PAPERS

---

## MATCH ALL SOURCES (ONLY SELECTED SOURCE PRINTED)

---

1%

★ Muhammad Fachrurrozi, Saparudin, Erwin. "Real Time Monitoring System of Pollution Waste on Musi River Using Support Vector Machine (SVM) Method", IOP Conference Series: Materials Science and Engineering, 2017

Publication

---

Exclude quotes Off

Exclude matches Off

Exclude bibliography Off